



Small inclinometers for measurements in the ranges of ± 10 , ± 30 and ± 70 degrees

Features

- linear output characteristics
- high measurement accuracy
- high long-term stability
- hysteresis free output signal
- minimal zero point drift
- integrated sensor electronics
- low power consumption
- small housing
- light weight
- different output signal options
- no interference by ambient electromagnetic fields
- shockproof as without moving mechanical parts
- hermetically sealed
- sensor electrically isolated from point of measurement using high quality plastic housing - no ground connections
- zero point adjustable through 360° using clamping ring

Description

The N2, N3 and N4 are capacitive, liquid based inclinometers with integrated sensor electronics. They are manufactured with an analog DC output. The sensor electronics require only minimal power and are in conjunction with the capacitive primary transformer characterized by high accuracy, a high signal-to-noise ratio and high long-term stability. The measurement technique enables a linear relationship between the angle to be measured and the output signal. The determined angle is independent of the local gravitational acceleration, that means that no matter where the measurement is being taken, whether in Europe, Australia, on Mount Everest or on the moon, the inclination will be measured correctly anywhere.

Application

The inclinometers N2, N3 and N4 are suitable for applications requiring a small, light sensor for measurement of relatively large inclinations. Typical areas of application include measuring instruments and inspection systems, vehicles, automation and safety engineering, scientific devices, medical and communications equipment as well as navigational systems.

Specifications

Type	N2	N3	N4
Measuring range	$\pm 10^\circ$	$\pm 30^\circ$	$\pm 70^\circ$
Resolution	<0,002°	<0,005°	<0,01°
Values for analog DC output at $U_b = 5$ Volt			
Sensitivity	approx. 12mV/degree	approx. 6mV/degree	approx. 3.6mV/degree
Temperature drift of sensitivity	approx. -0.19%/K	approx. -0.17%/K	approx. -0.17%/K
Temperature drift of zero point	approx. ± 0.05 mV/K	approx. ± 0.025 mV/K	approx. ± 0.025 mV/K

Shared specifications	
Dimensions	see dimension drawing
Linearity deviation	0,2% of measuring range
Transverse sensitivity	<1% at 30° tilt
Settling time	<0,3 seconds
Nominal supply voltage (regulated externally)	$U_{bN} = 5 \text{ Volt}$
Permissible supply voltage range U_{bz}	3V ... 6V
Mechanical overload resistance	10 000 g (approx. 100 000 m/s ²)
Degree of protection	IP 65
Operating temperature	-40°C ... +85°C
Storage temperature	-45°C ... +90°C
Weight (without clamping ring, with approx. 18cm wires)	approx. 24g
Electrical connection	standard: • 3 highly flexible, color-coded wires $\varnothing \sim 1\text{mm}$, length approx. 18 cm <hr/> optional: • 0.5m strong, flexible, shielded cable, 2 wires + shield, $\varnothing 2,1\text{mm}$ • special lengths on request
Values for analog DC output at $U_b = 5 \text{ Volt}$	
Current drawn	approx. 1mA
Zero offset	$2.5 \pm 0,1 \text{ Volt}$ - generally: $0.5U_b \pm 4\%$
Output impedance	10 kOhm

- Each sensor is calibrated after production. It is delivered with an individual calibration record that includes the precise offset and sensitivity values, the static characteristic curve and the linearity deviation curve.
- On request: PWM-output

Dimensions (in mm) and Connections

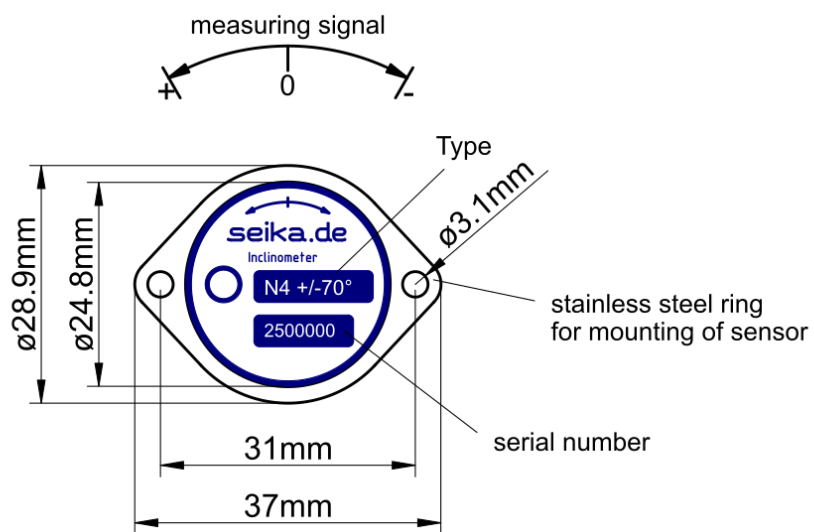
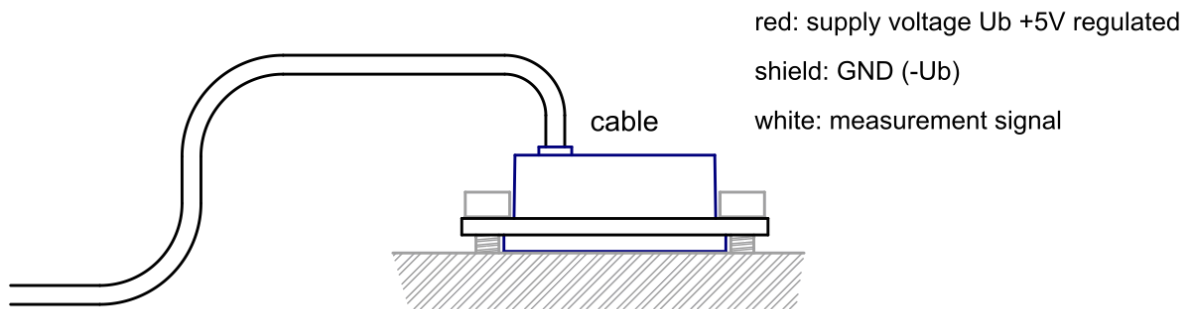
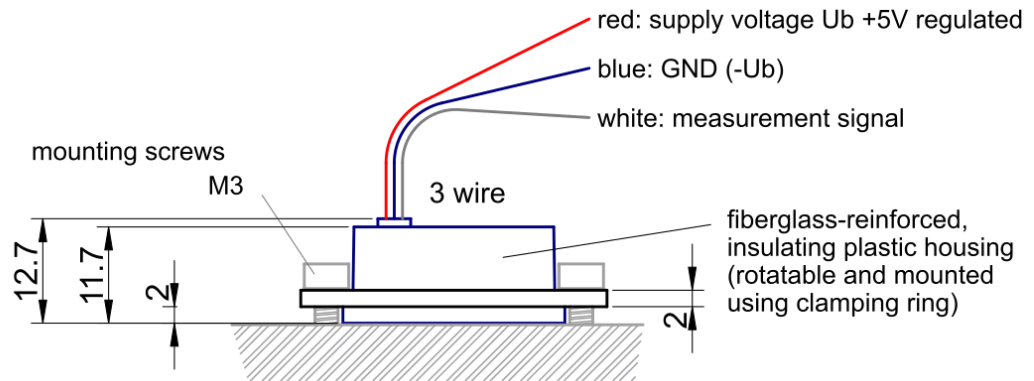

Attention! The supply voltage must not exceed 6 Volt and the polarity must not be reversed.

Cable assignment: red: 5V, white: output, shield: GND.