

Filtering signal conditioner for sensor signal matching to a 4...20mA, 2-wire interface

Features

- low noise and low drift
- 2-wire connection - power supplied by current loop
- loop current limitation
- integrated reverse polarity protection
- highly stable sensor supply voltage
- zero position and gain adjustable via potentiometers
- electronic components hermetically sealed
- optionally frequency programmable, active 3rd order low pass filter
- optional high pass filter
- different connector options

Description

The NV6a amplifies, filters and normalizes the output signals of SEIKA sensors. The output signal enables unproblematic subsequent signal processing on the basis of 4...20mA current loop technology. The NV6a does not require a separate supply voltage, as the internal operating voltage feeds off the current loop. The NV6a furthermore provides a highly stable 5V sensor supply voltage with short circuit current limitation. Multiple internal switching variants allow for optimal adaptation of signal processing parameters, such as settling time, filter cut-off frequencies and amplification and zero point adjustment, to the measuring task.

Application

The NV6a has its application anywhere a SEIKA sensor is, without much expenditure and under optimal compatibility, to be connected to measuring equipment operating on 4...20mA, 2-wire current loop basis and subsequent adjustment of amplification and zero position are necessary. Typical applications are the coupling with memory programmable control systems and the signal transmission over long distances with little transmission line setup.

Specifications

Dimensions	see dimension drawing
Terminal voltage	+8 ... +30 Volt (reverse polarity protected to -70 Volt)
Minimum loop current excluding sensor	2.5mA ... 3.5mA
maximum loop current	22mA ... 26mA
Operating temperature	-40°C ... +85°C
internally generated sensor supply voltage	+5.00 Volt
Temperature drift of sensor supply voltage	5 ppm/K
maximum allowable sensor current	approx. 2mA
Signal loop current range	4...20mA
Zero current	12mA
Compensation range of sensor offset voltage U_{S_offset}	2.3 ... 2.7 Volt (larger ranges, e.g. for B1 in Z-direction, on request)
Amplification range with respect to a loop current of 12 ± 8 mA	$U_{S_offset} \pm 100$ mV, on request: $U_{S_offset} \pm 300$ mV
maximum load resistance at 24V supply voltage	500 Ohm
Thermal noise	30μ V _{p.p.}
Signal-to-noise ratio with standard sensors	>65dB
Frequency range	0...10Hz, 0...200Hz, 0...1kHz; custom ranges on request
Electrical connections	pin connector 2.54mm, length 5.7mm, Ø 0.63mm gold-plated soldering pads optional
Weight	approx. 11g

Dimensions (in mm)

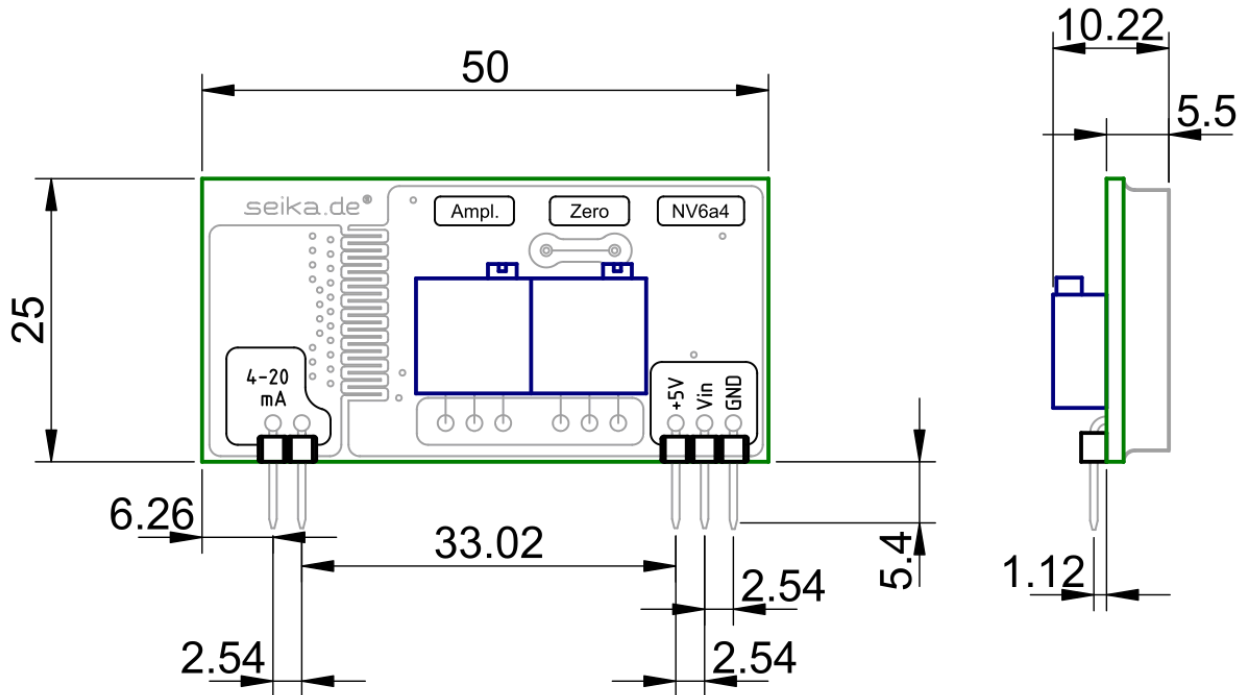

Connections

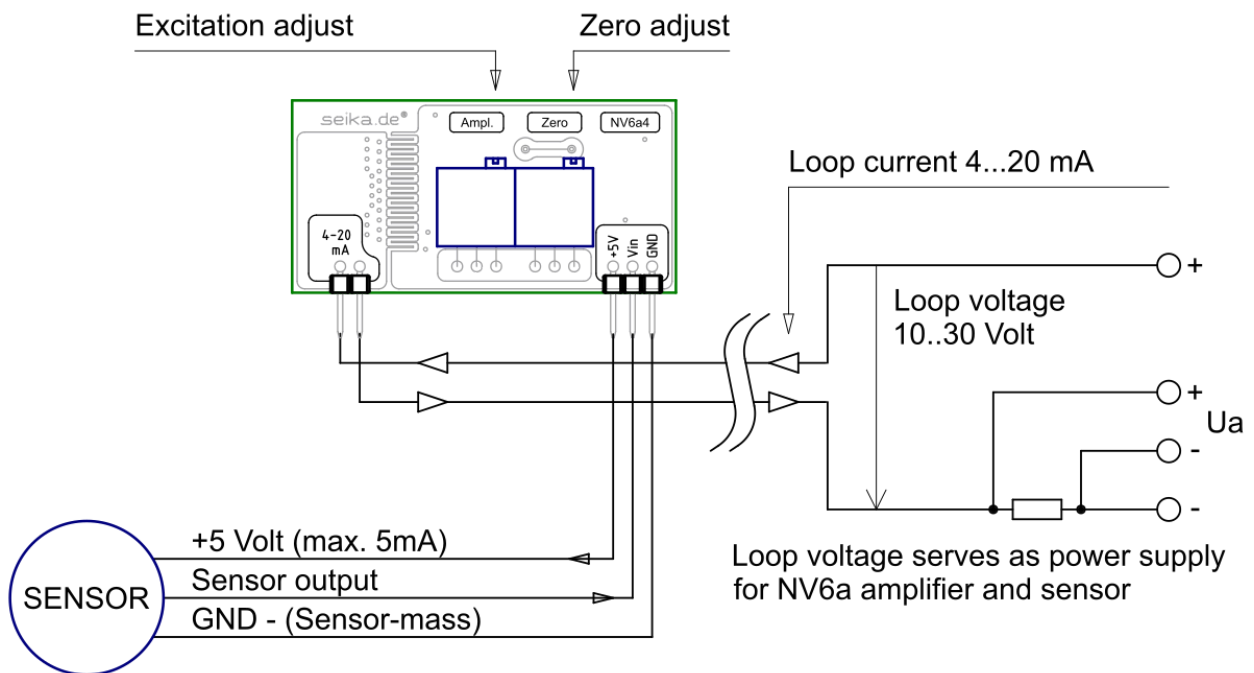

Attention! Sensor GND and NV6a GND (both at same potential) must be isolated from the current loop!
 In a multiaxial arrangement (e.g. SW3), all sensor grounds must be isolated from each other. When ordering, please state "sensor internally insulated, for NV6a compatibility" on your order in particular for the B-, BDK-, and NB-series of sensors with a metal housing. This restriction is not applicable to signal conditioners with voltage output (NV4a, NV8a, NG..U, etc.). Since the supply voltages for the NV6a and the sensor feed off the current loop (they require at least 3mA), a terminal voltage of 8V to

the NV6a must be guaranteed in order to ensure proper functionality even for the maximum loop current of approx. 24mA (highest voltage drop across load resistance).